

PCD-320/330/430 Series Conveyor (Horizontal to Decline)

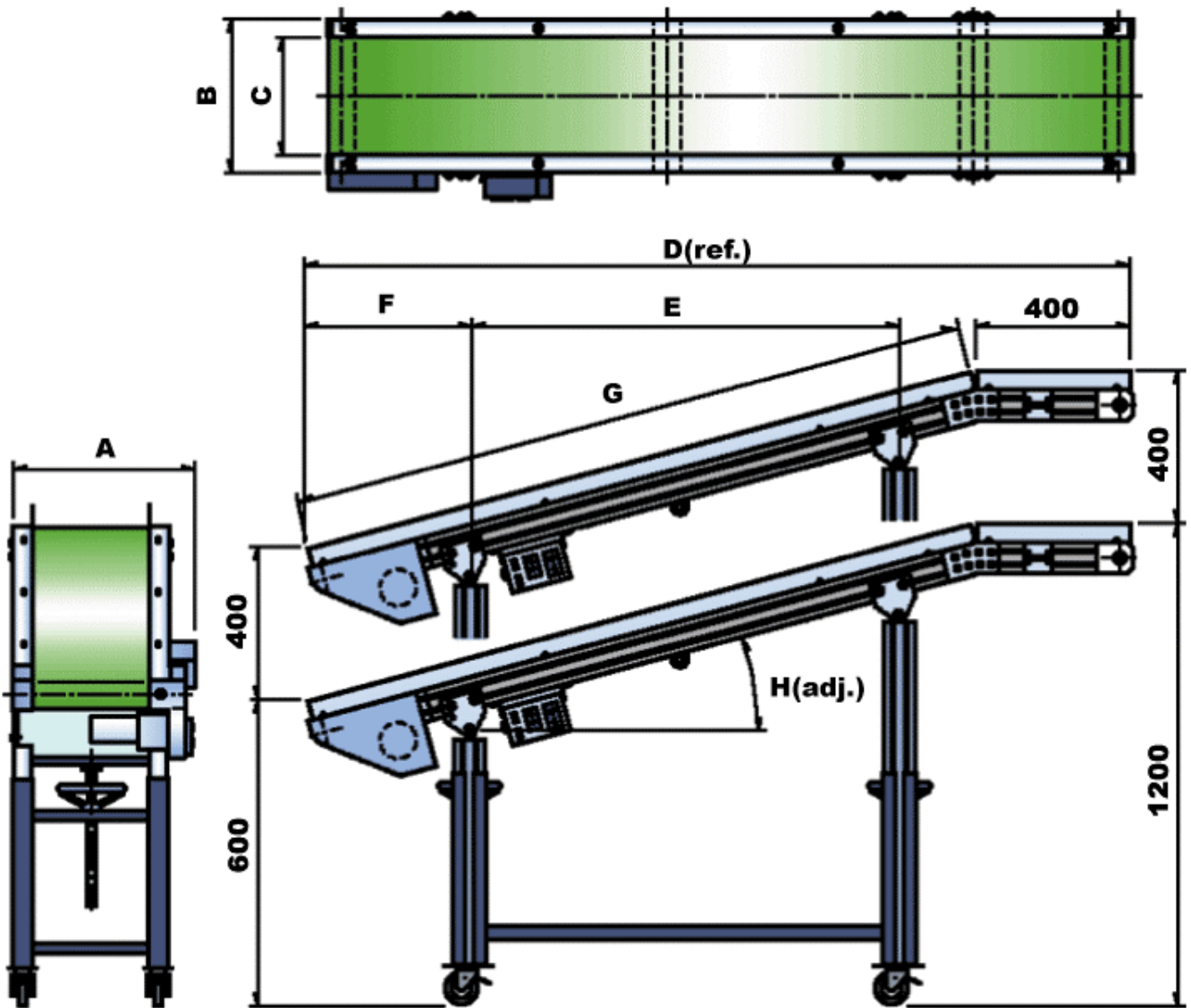

Model	PCD-320	PCD-330	PCD-430
A	425	425	525
B	380	380	480
C	300	300	400
D	2307	3339	3339
E	1500	2000	2000
F	350	550	550
G	2000	3000	3000
H	14.9°	13.4°	13.4°

Unit: mm

Belt Speed*	0~4.8m/minute(variable)
Motor driving power	60W
Voltage (phase)	220V/240V (1Ø)

*Based on 60hz operations.

PCD-440/540/550 Series Conveyor (Horizontal to Decline)

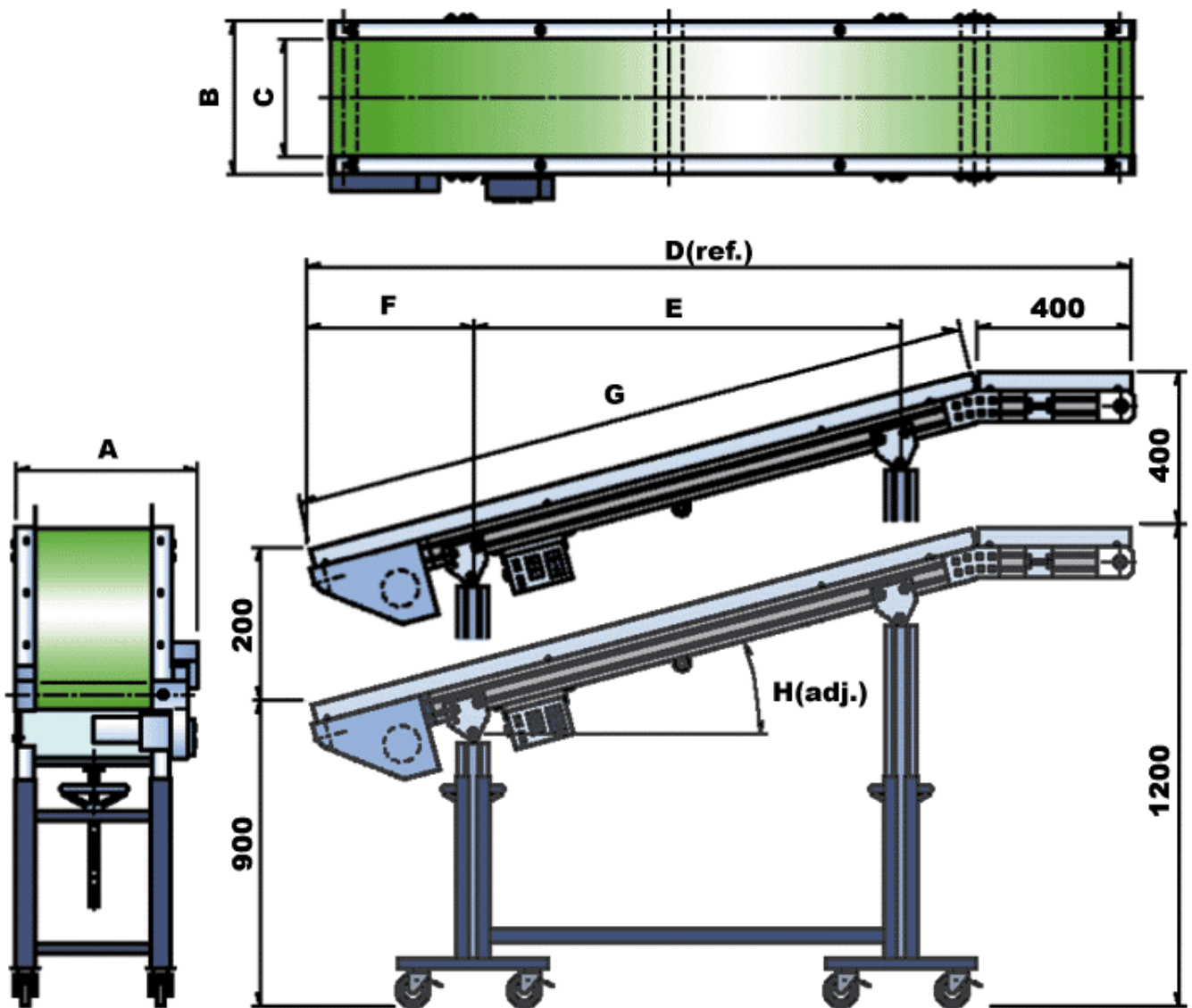

Model	PCD-440	PCD-540	PCD-550
A	525	625	625
B	480	580	580
C	400	500	500
D	4355	4355	5364
E	3000	3000	4000
F	600	600	600
G	4000	4000	5000
H	8.6°	8.6°	6.9°

Unit: mm

Belt Speed*	0~4.8m/minute(variable)
Motor driving power	90W
Voltage (phase)	220V/240V (1Ø)

*Based on 60hz operations.