

# PCF Series Conveyor (Standard Straight)

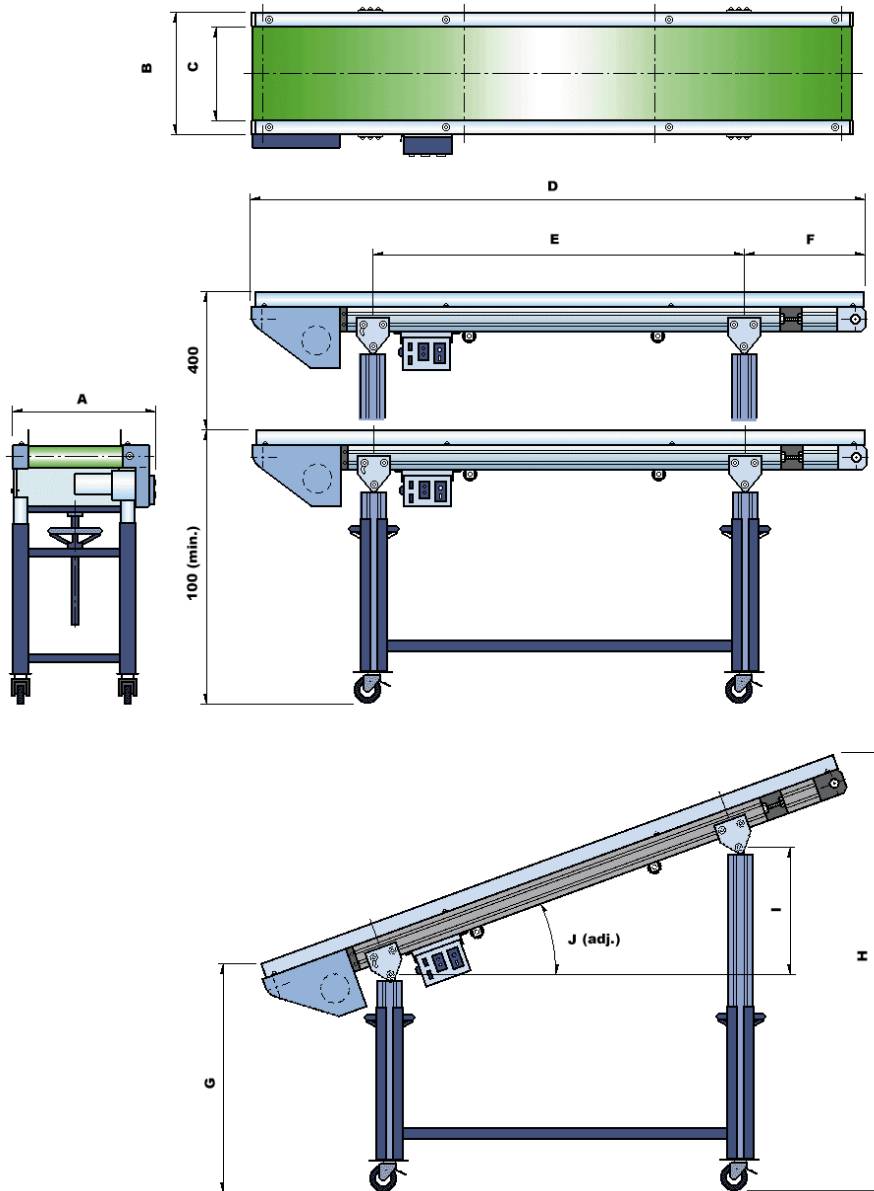

Model	A	B	C	D	E	F	G	H	I	J
PCF-320	425	380	300	2000	1200	400	Min.883	Max.1468	Max.350	Max.16.3°
PCF-330	425	380	300	3000	2100	450	Min.925	Max.1427	Max.350	Max.9.5°
PCF-430	525	480	400	3000	2100	450	Min.925	Max.1427	Max.350	Max.9.5°
PCF-440	525	480	400	4000	3000	500	Min.941	Max.1411	Max.350	Max.6.7°
PCF-540	625	580	500	4000	3000	500	Min.941	Max.1411	Max.350	Max.6.7°
PCF-550	625	580	500	5000	4000	500	Min.956	Max.1384	Max.350	Max.5°

Unit:mm

Belt Speed *	0~4.8m/minute (variable)
Motor driving power	PCF320/330/430-60W PCF440/540/550-90W
Voltage (phase)	220V/240V (1Ø)

\* Based on 60hz operations.